

**Calculus Honors
Summer Assignment 2010**

Due Date: First Day of School

Complete all exercises neatly in the space provided. This will be graded and count as the first TEST GRADE of the marking period. All answers must be supported by your work. Turn in your completed assignment to me by the above due date. Late assignments will NOT be accepted.

Plot the points and find the slope (if any) of the line they determine.

- 1) A(6, -7), B(-3, -2)

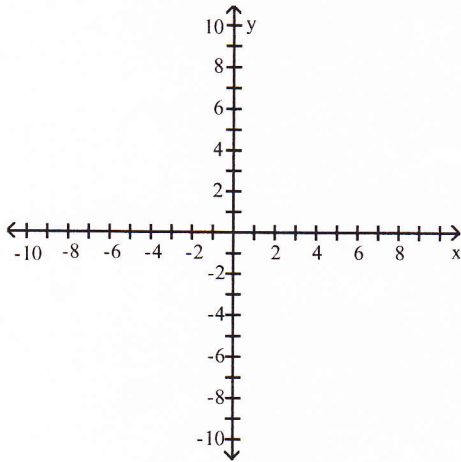

Find an equation for the vertical line and the horizontal line through the given point.

2) $\left(-1, \frac{1}{9}\right)$

Write an equation for the line described.

3) Passes through $(2, 3)$ with slope $-\frac{3}{8}$

4) Passes through $(9, -4)$ and $(4, -6)$

5) Passes through $(2, 5)$ and perpendicular to the line $-9x - 4y = -38$

6) Passes through (7, -7) and is parallel to the line $2x - 3y = 8$

Find the formula for the function.

7) Express the volume of a sphere as a function of its radius r .

Find the domain and range.

8) $y = \sqrt{7 + x}$

9) $f(x) = \frac{6}{3 - x}$

Graph the piecewise-defined function.

10)

$$y(x) = \begin{cases} 8x + 8, & \text{if } x < 0 \\ 4x^2 - 3, & \text{if } x \geq 0 \end{cases}$$

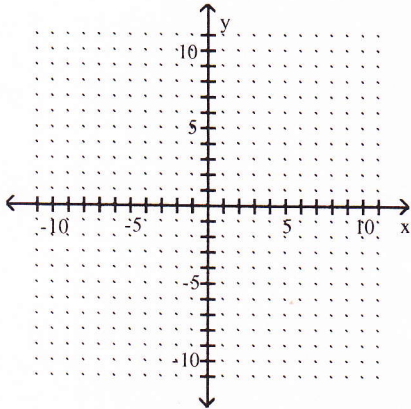

Graph the function.

11) $y = (x - 4)^{2/3}$

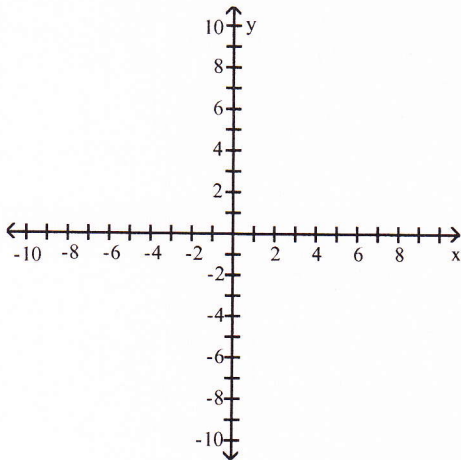

$$12) y = \frac{1}{x^2} + 2$$

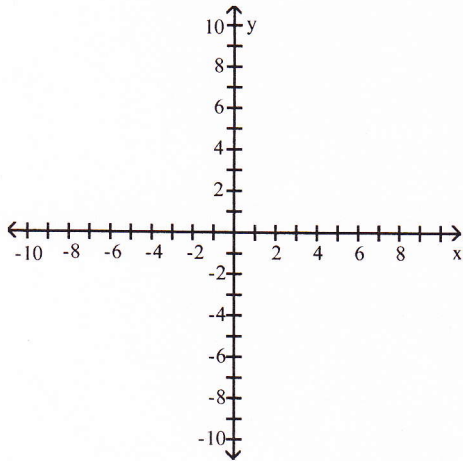

Solve the problem.

13) If $f(x) = 4x^2 + 2x + 5$ and $g(x) = 2x - 4$, find $g(f(x))$.

14) If $(f \circ g)(x) = \frac{1}{\sqrt{x} - 5}$ and $f(x) = \frac{1}{x - 5}$, find $g(x)$.

- 15) A box with an open top is to be constructed from a rectangular piece of cardboard with dimensions 14 inches by 22 inches by cutting out equal squares of side x at each corner and then folding up the sides as in the figure. Express the volume V of the box as a function of x .

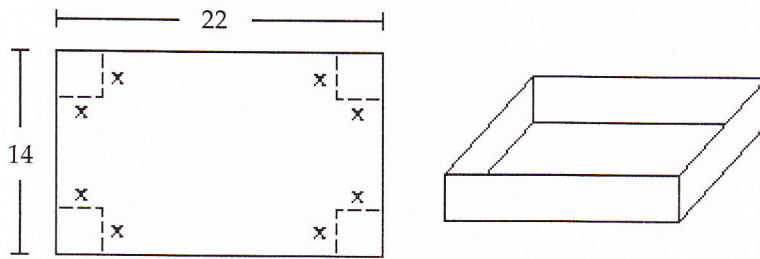

Graph the exponential function.

16) $y = 2^x$

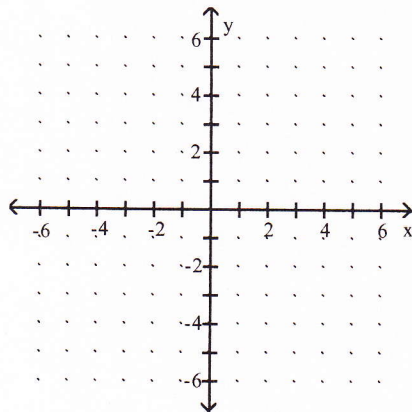

Rewrite the exponential expression to have the indicated base.

17) $\left(\frac{1}{8}\right)^{3x}$; base 2

Use your grapher to find the zero of the function. Round your answer to three decimal places.

18) $f(x) = 10 - 2^x$

Solve the problem.

19) How long will it take for the population of a certain country to double if its annual growth rate is 2.2%? Round to the nearest year.

Find the inverse of the function.

20) $f(x) = x^3 + 2$

Solve the equation.

21) $(7.31)^t = 7$

22) $e^{0.79000001 t} = 19$

23) $\ln(y + 5) - \ln 7 = x + \ln x$; Solve for y.

For a radius r, arc length s, and angle θ , find the indicated quantity.

24) $r = 19.10$ cm, $\theta = 2.30$ radians, find s

Determine if the function is even or odd.

25) cosine

Find the requested function value meeting all of the given conditions.

26) $\cos \theta = -\frac{\sqrt{2}}{2}$ and $\tan \theta > 0$; Find $\sin \theta$.

Find the requested value or interval.

27) Find the period of $y = \sin 5x$

Graph the function.

28) $y = -\sec x$

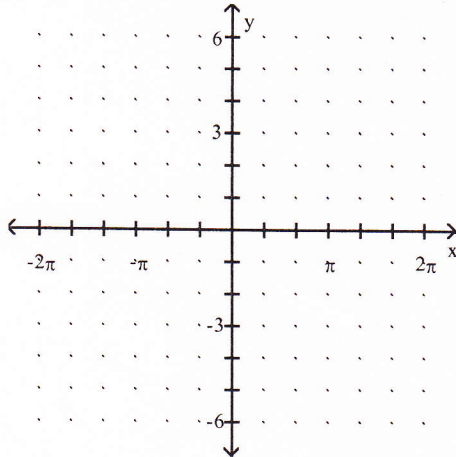

Find the exact value of the real number y .

29) $y = \sin^{-1}\left(\frac{\sqrt{2}}{2}\right)$

Find the indicated trigonometric function, given that θ is an angle in standard position with the terminal side passing through the given point.

30) $(9, 4)$; Find $\sec \theta$.